

MOOG

Differential Proportional Flow Control Valve DPCMEE 16 & 20

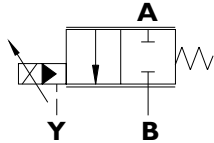

Table of Contents

Designation	Symbol	Page
General Description and Operating Principle		4
Specifications		5
Performance Data DPCMEE16 - CK; EK and DK Cones		6
Response Characteristics Frequency & Step Response- DPCMEE16		7
Performance Data DPCMEE20 - CK; EK and DK Cones		8
Response Characteristics Frequency & Step Response- DPCMEE20		9
Standard Models		10
Dimensions Valve & Cavity Dimensions - DPCMEE16		11
Dimensions Valve & Cavity Dimensions - DPCMEE20		12
Ordering Information		13
Spare Parts		14

General Description and Operating Principle

DESCRIPTION:

Moog's DPCME series differential proportional flow control valves are used to regulate flow from 'A' port to 'B' port. This valve uses a self-regulating hydraulic design for control of flow rate by a current-controlled PWM signal. This screw-in cartridge type valve is designed to fit in SAE style cavity with UN thread for use in manifolds. It can also be used in conjunction with 2- or 3- way pressure compensators as a 2- or 3- way pressure compensated flow control valve.

OPERATING PRINCIPLE:

This valve is in a normally closed condition. In the closed condition the pressure of the fluid at the 'A' port is sensed through the orifice (2) and acts on the main spool (1). Since the pilot spool (4) is a pressure balanced design, the main spool is held closed due to the hydraulic pressure and the spring (3) force. When a current signal is applied to the valve, the proportional solenoid (5) extends. The force of the solenoid (5), which is directly proportional to the applied signal, pushes the pilot spool (4) downwards. At this time the pilot spool (4) connects the pilot side flow to the tank port internally, thus creating a pressure drop across the orifice (2). This will allow the main spool to move upwards, allowing flow from 'A' port to 'B' port. As the main spool (1) opens, the forces become unbalanced between the spring (3) and solenoid (5) acting on the pilot spool (4). At which time this force balance is reestablished, the main spool (1) stops moving. This allows the valve to be used for proportionally controlling the flow by steplessly varying the input current signal.

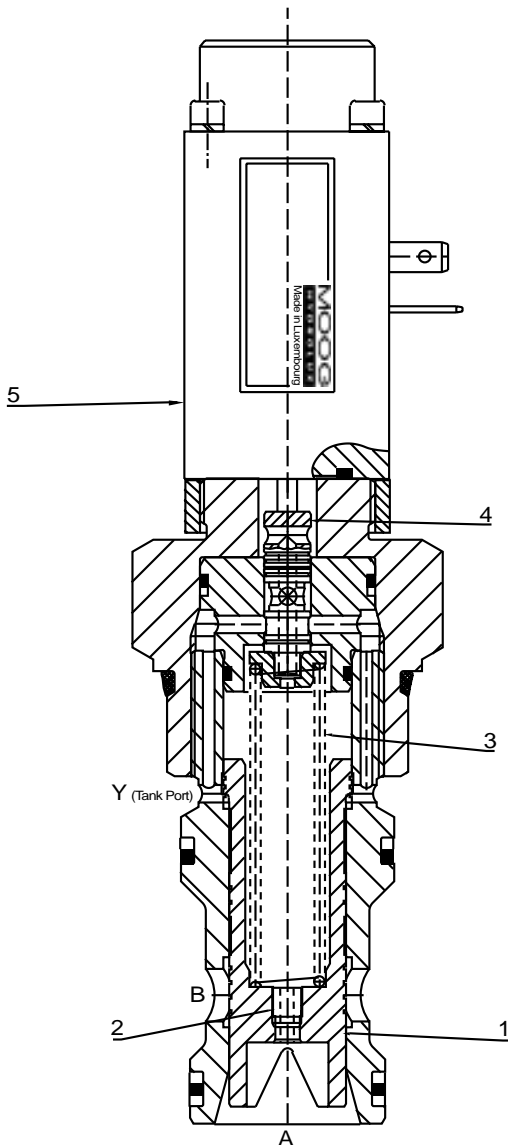

General Data	Value	Unit	Specifications
Designation			Differential-proportional flow control valve
Type Designation			Refer to Ordering Information page 13
Mode of Construction			Cartridge-Screw-in-Valve
Mounting Style			Manifold Mounting
Branch Circuit Connection			Drillings in the Manifold
Mounting Dimensions		mm	See page 11 and 12
Mounting Position			Any
Flow Direction			A → B
Ambient Temperature Range	min.	°C / °F	-25 / -13
	max.	°C / °F	+60 / +140
Working Pressure			
Input	min.	bar/psi	0 / 0
	max.	bar/psi	350 / 5075
Outlet	min.	bar/psi	0/0
	max.	bar/psi	350 / 5075
Fluid Temperature Range	min.	°C / °F	-25 / -13
	max.	°C / °F	+80 / +176
Viscosity Range	min.	cSt/E	2.8 / 1.2
	max.	cSt/E	380 / 50
Operational Viscosity	Vn	cSt/E	35 / 4.66
Connection Bore = Size (mm)			See page 11 and 12
Weight of Typical Assembly		kg (lb)	See page 10
Nominal Flow	Qn	l/min	See Page 6 and 8

Performance Data

Performance Curve DPCMEE16S8 – Cone – CK

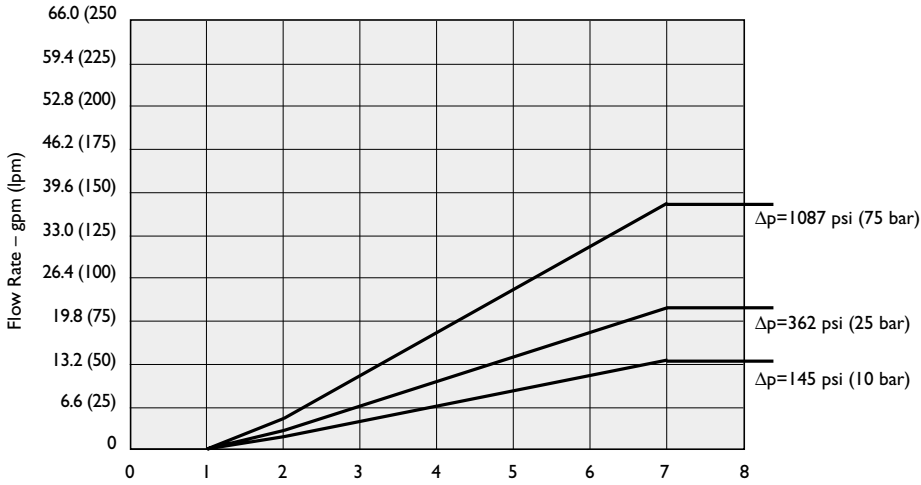

Formula:

To calculate flow at different pressure drops, use the following formula:

$$Q_x = Q_{\Delta p_{10}} \sqrt{\frac{\Delta p_x}{10}}$$

Where:

Q_x = Flow at pressure drop Δp_x -lpm

$Q_{\Delta p_{10}}$ = Flow at 10 bar pressure drop (from the curves)

Δp_x = Pressure drop in bar at which flow is calculated

Performance Curves DPCMEE16S8 – Cone – EK

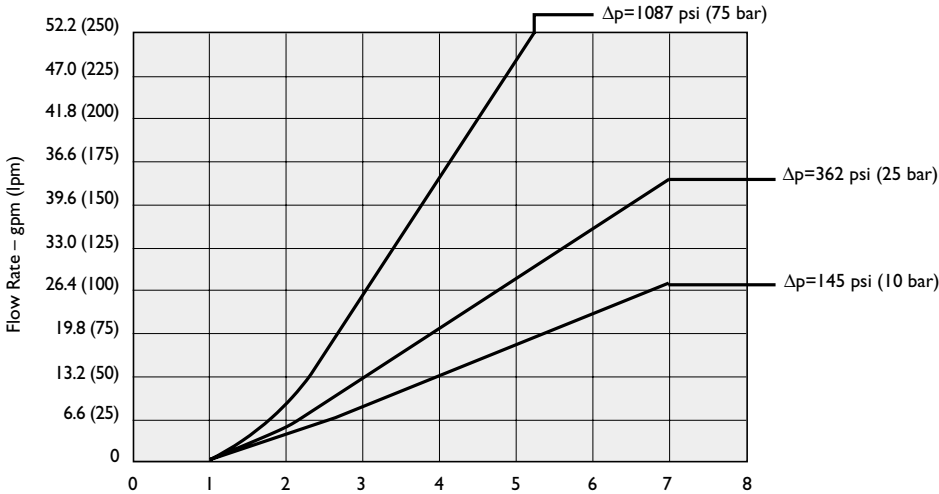

Performance Curves DPCMEE16S8 – Cone – DK

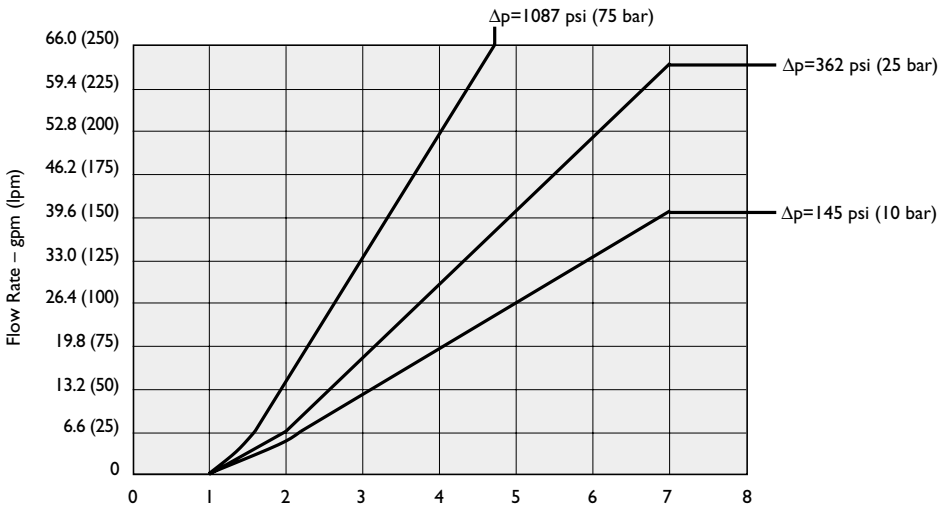

Frequency Response – DPCMEE16S8

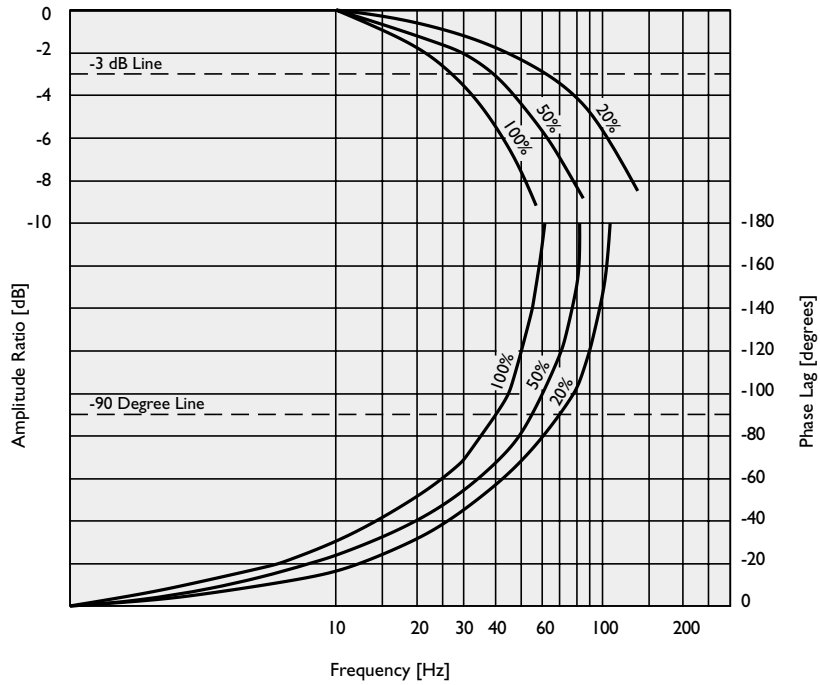

Current vs Stroke Characteristic Curve DPCMEE16S8

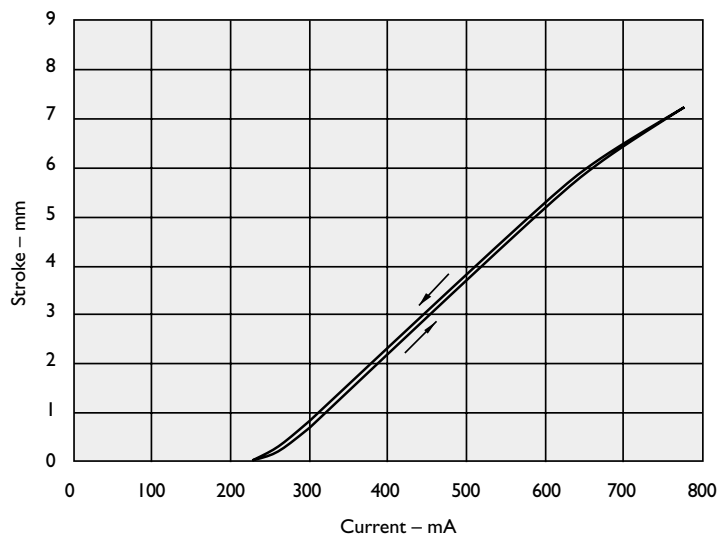

Performance Data

Performance Curves – DPCMEE20S8 – Cone – CK

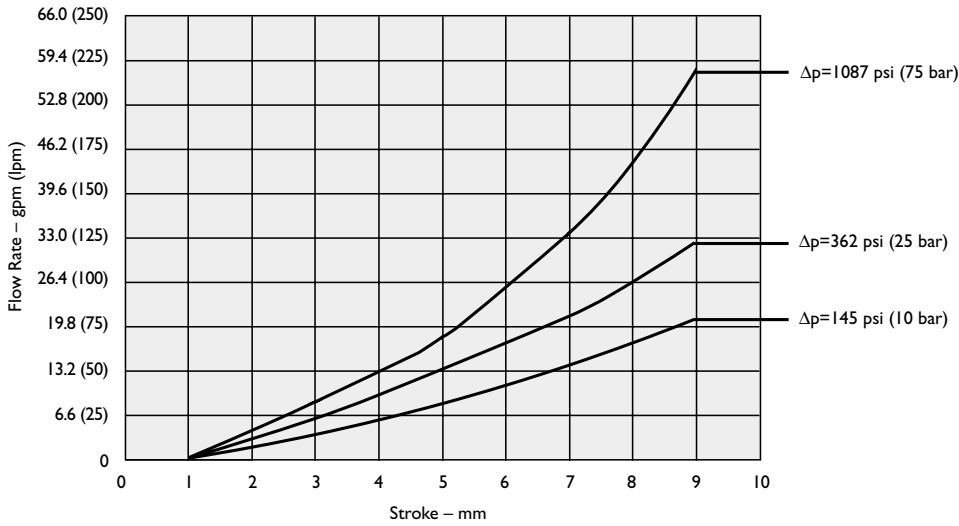

Formula:

To calculate flow at different pressure drops, use the following formula:

$$Q_x = Q_{\Delta p 10} \sqrt{\frac{\Delta p_x}{10}}$$

Where:

Q_x = Flow at pressure drop Δp_x -lpm

$Q_{\Delta p 10}$ = Flow at 10 bar pressure drop (from the curves)

Δp_x = Pressure drop in bar at which flow is calculated

Performance Curves – DPCMEE20S8 – Cone – EK

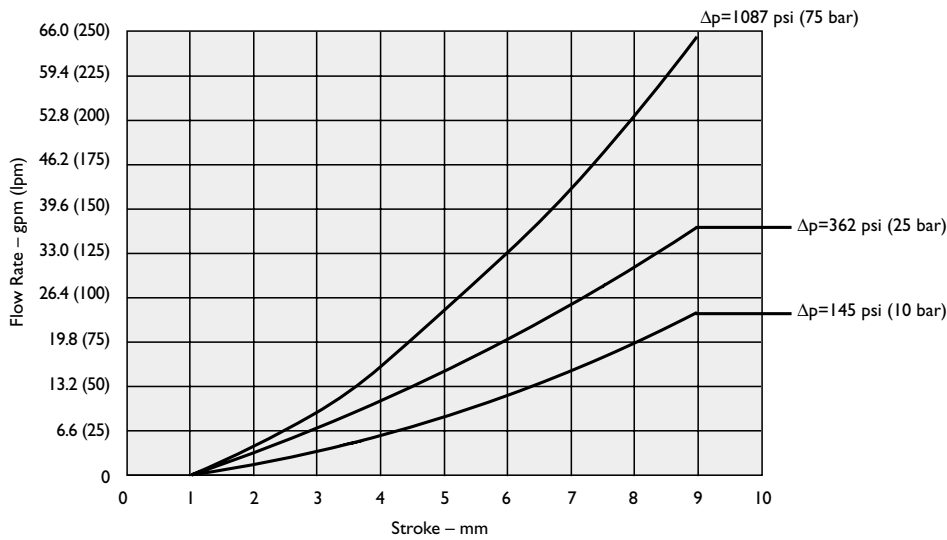

Performance Curves – DPCMEE20S8 – Cone – DK

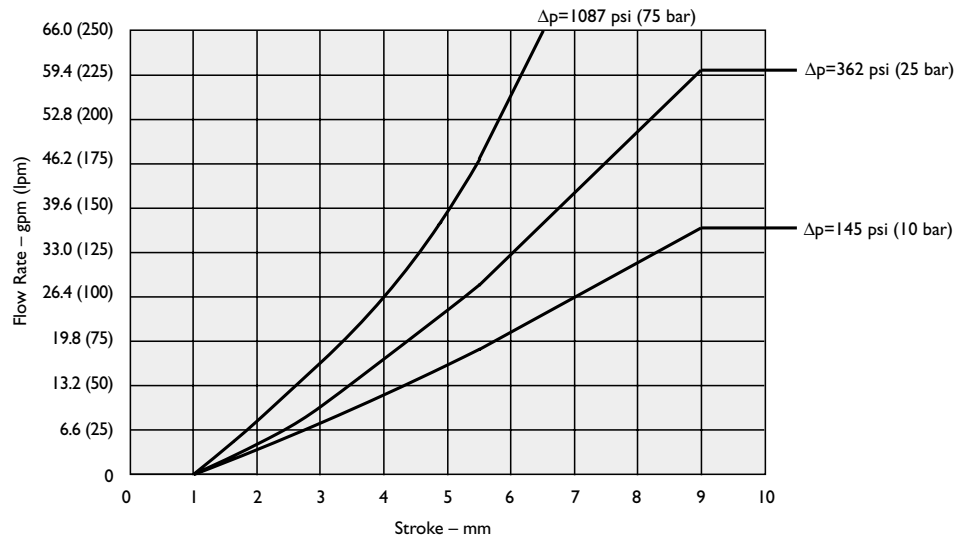

Frequency Response – DPCMEE20S8

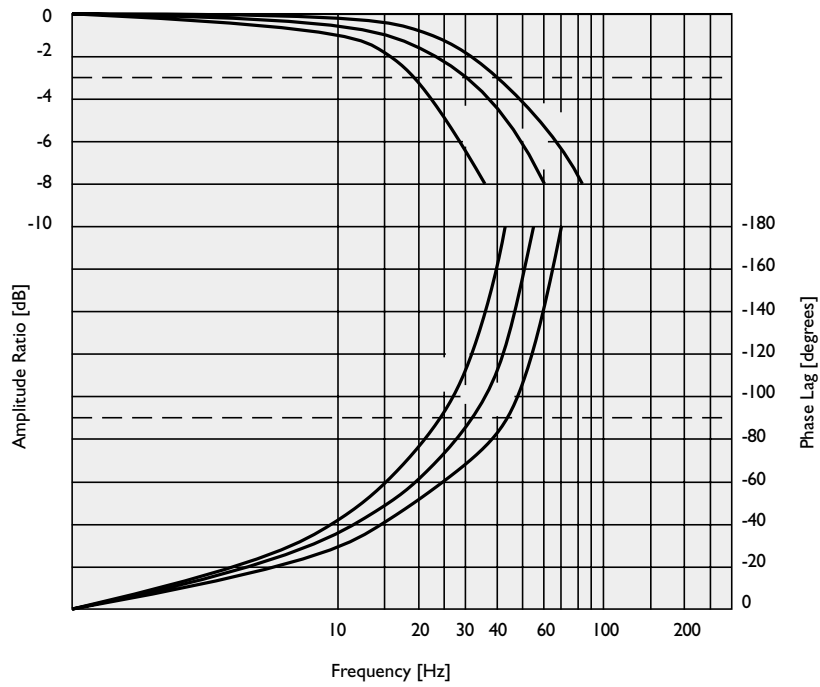

Current vs Stroke Characteristic Curve DPCMEE20S8

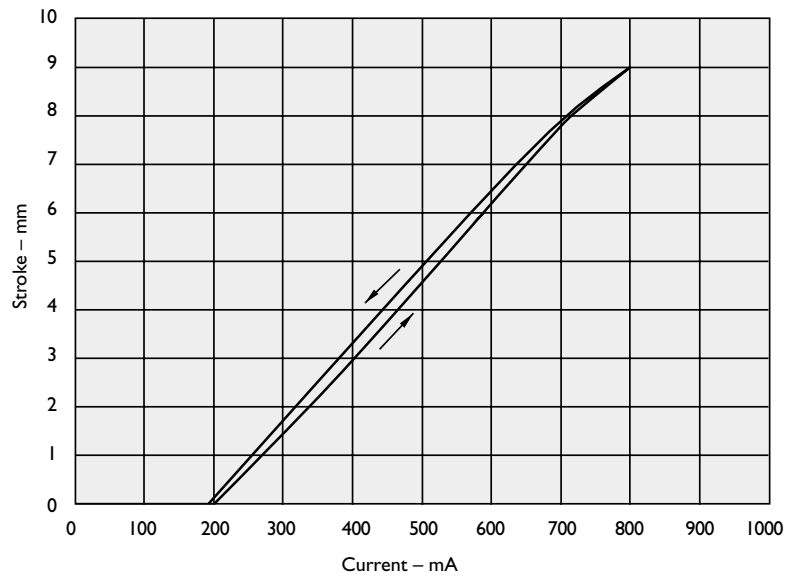

Standard Models

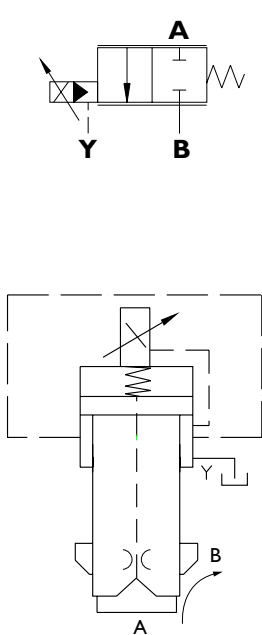
Symbol	Function	Nominal Size*	Weight lb. (kg)	Part Designation	Part Number
	Proportional Throttle	16	2.60 (1.2)	DPCMEE16S8CK0ZS3A	XDB10424-000-01
				DPCMEE16S8CK0ZS3B	XDB10108-000-01
				DPCMEE16S8EK0ZS3A	XDB10423-000-01
				DPCMEE16S8EK0ZS3B	XDB10107-000-01
				DPCMEE16S8DK0ZS3A	XDB10425-000-01
				DPCMEE16S8DK0ZS3B	XDB10109-000-01
		20	3.25 (1.5)	DPCMEE20S8CK0ZS3A	XDB10462-000-01
				DPCMEE20S8CK0ZS3B	XDB10110-000-01
				DPCMEE20S8EK0ZS3A	XDB10461-000-01
				DPCMEE20S8EK0ZS3B	XDB10111-000-01
				DPCMEE20S8DK0ZS3A	XDB10463-000-01
				DPCMEE20S8DK0ZS3B	XDB10112-000-01

*Nominal size refers to the Standard Industrial "Short Series" screw-in cavities. Refer to pages 11 & 12 for cavity details.

Ordering Information

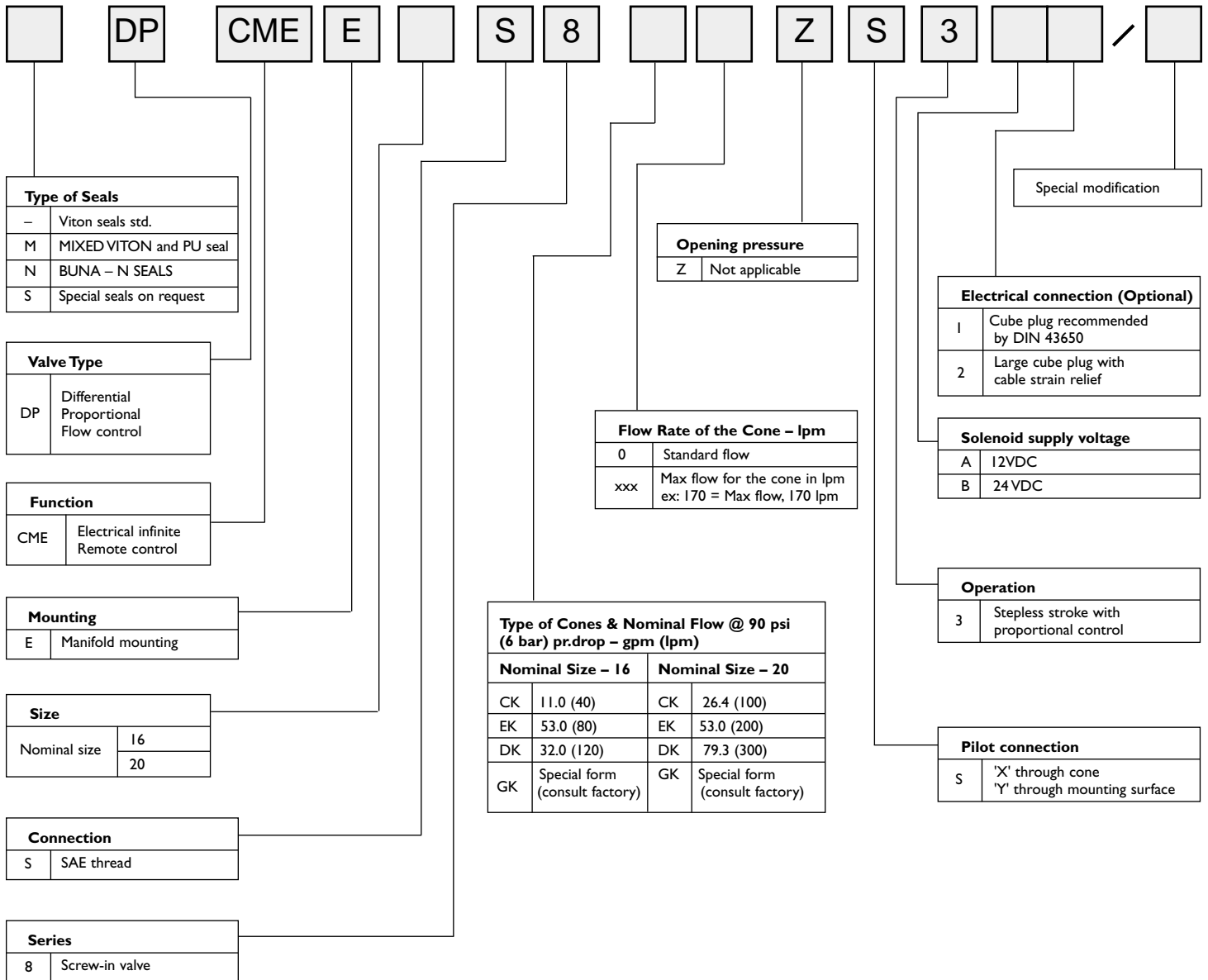

Type of Seals	
-	Viton seals std.
M	MIXED VITON and PU seal
N	BUNA - N SEALS
S	Special seals on request

Valve Type	
DP	Differential Proportional Flow control

Function	
CME	Electrical infinite Remote control

Mounting	
E	Manifold mounting

Size	
Nominal size	16
	20

Connection	
S	SAE thread

Series	
8	Screw-in valve

Opening pressure	
Z	Not applicable

Flow Rate of the Cone - lpm	
0	Standard flow
xxx	Max flow for the cone in lpm ex: 170 = Max flow, 170 lpm

Type of Cones & Nominal Flow @ 90 psi (6 bar) pr.drop - gpm (lpm)			
Nominal Size - 16		Nominal Size - 20	
CK	11.0 (40)	CK	26.4 (100)
EK	53.0 (80)	EK	53.0 (200)
DK	32.0 (120)	DK	79.3 (300)
GK	Special form (consult factory)	GK	Special form (consult factory)

Special modification

Electrical connection (Optional)	
1	Cube plug recommended by DIN 43650
2	Large cube plug with cable strain relief

Solenoid supply voltage	
A	12VDC
B	24VDC

Operation	
3	Stepless stroke with proportional control

Pilot connection	
S	'X' through cone 'Y' through mounting surface

Spare Parts

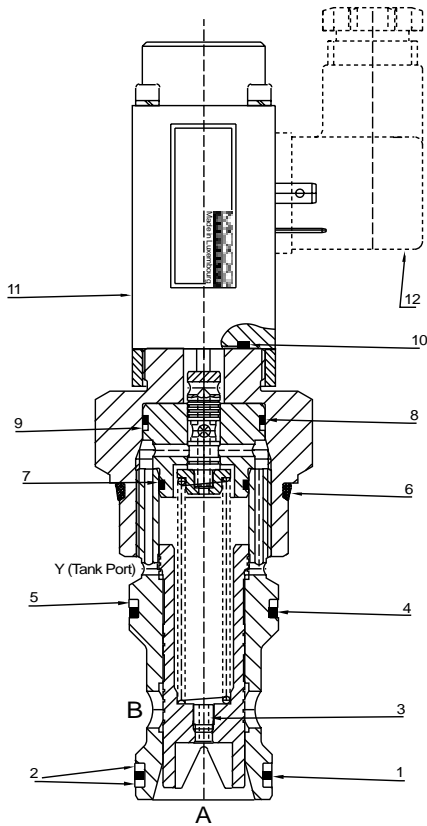

PARTS LIST				
Position #	Quantity	Designation	Part Number	
			DPCMEE16S8	DPCMEE20S8
-	1	Seal Kit	XEB12544-000-00	XEB13696-000-00
1	1	O-ring, Viton 21.95 x 1.78	X980-02020	
	1	O-ring, Viton 28.24 x 2.62		X980-02122
2	2	Back-up Ring	X783-00062	
	2	Back-up Ring		X783-00077
3	1	Orifice M5 x 5 x 1.0	X784-90510	
4	1	O-ring, Viton 23.47 x 2.62	X980-02119	
	1	O-ring, Viton 31.42 x 2.62		X980-02124
5	1	Back-up Ring	X783-00030	
	1	Back-up Ring		X783-00078
6	1	O-ring, Viton 29.82 x 2.62	X980-02123	
	1	O-ring, Viton 37.77 x 2.62		X980-02128
7	1	O-ring, Viton 12.42 x 1.78	X980-02014	
	1	O-ring, Viton 18.77 x 1.78		X980-02018
8	1	O-ring, Viton 20.35 x 1.78	X980-02019	
	1	O-ring, Viton 26.70 x 1.78		X980-02023
9	1	Back-up Ring	X783-00043	
	1	Back-up Ring		X783-00079
10	1	O-ring, Viton 18.77 x 1.78	X980-02018	
	1	O-ring, Viton 18.77 x 1.78		X980-02018
11	1	Prop. Solenoid - 12 V DC	X788-10126	
	1	Prop. Solenoid - 24 V DC	X788-10243	
12*	1	Plug-in Connector w/o LED, DIN 43650 / ISO 4400 (PG9)-Black	X798-00004	
	1	Plug-in Connector w/o LED, DIN 43650 / ISO 4400 (PG9)-Grey	X798-00005	
	1	Big Plug-in Connector w/o LED, DIN 43650 / ISO 4400 (PG11)-Black	XEB16580-000-00	
	1	Big Plug-in Connector w/o LED, DIN 43650 / ISO 4400 (PG11)-Grey	XEB16577-000-00	
	1	Big Plug-in Connector with LED and free wheeling, DIN 43650 / ISO 4400 (PG11)-Black	XEB16581-000-00	
	1	Big Plug-in Connector with LED and free wheeling, DIN 43650 / ISO 4400 (PG11)-Grey	XEB16578-000-00	

Recommended Amplifiers* †

-	1	HAN 209 - 10 - 08 (for use with 24VDC supply voltage coils only) - Eurocard style 100 x 160 mm	X798-02005
		HAN 209 - 10 - 16 (for use with 12VDC supply voltage coils only) - Eurocard style 100 x 160 mm	X798-02006
		SKDHD32S - Card Holder for above.	X798-02013
		STV1010 - Plug-in box IP65 rated (for use with 24 VDC supply voltage coils only) 104 x 45 x 51 mm	X798-02060
		STV1010 - Plug-in box IP65 rated (for use with 12 VDC supply voltage coils only) 104 x 45 x 51 mm	X798-02061
		Snap-on module EM1020 (only for use with 24VDC supply voltage coil models) 79 x 74 x 22.5	X798-02031

*OPTIONAL – Not part of delivery.

† Refer to data sheets for details.



Argentina
Australia
Austria
Brazil
China
England
Finland
France



Germany
India
Ireland
Italy
Japan
Korea
Luxembourg
Norway
Russia
Singapore
Spain
Sweden
USA

MOOG
Industrial Controls Division

Moog Inc., East Aurora, NY 14052-0018
Telephone: 716/655-3000
Fax: 716/655-1803
Toll Free: 1-800-272-MOOG
www.moog.com